

Innovation in power conversion



Product Selector Guide

AC-DC Products

February 2011

C6
17 μF
35 V

D7
1148

1F
/ PC



Product Selector Guide

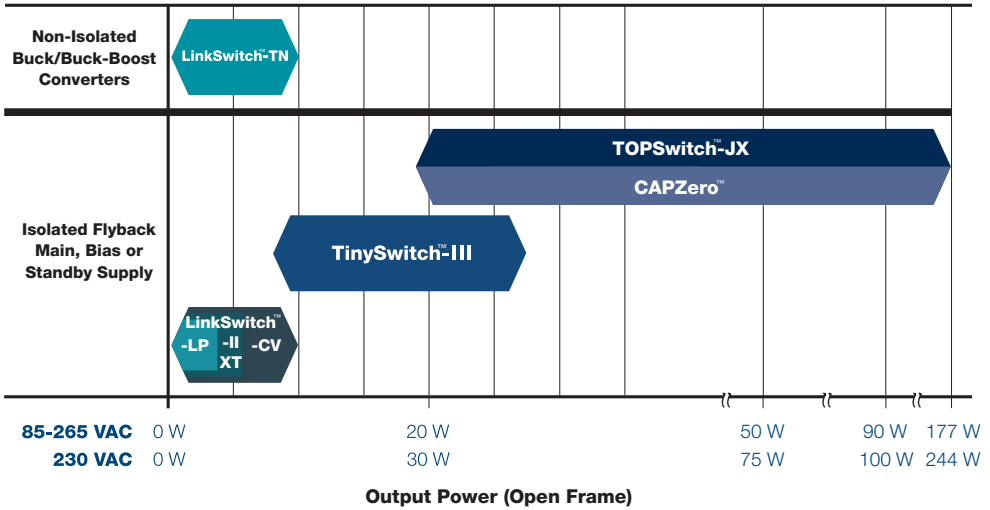

Output Characteristic Requirements (Wide Input 85 – 265 VAC)

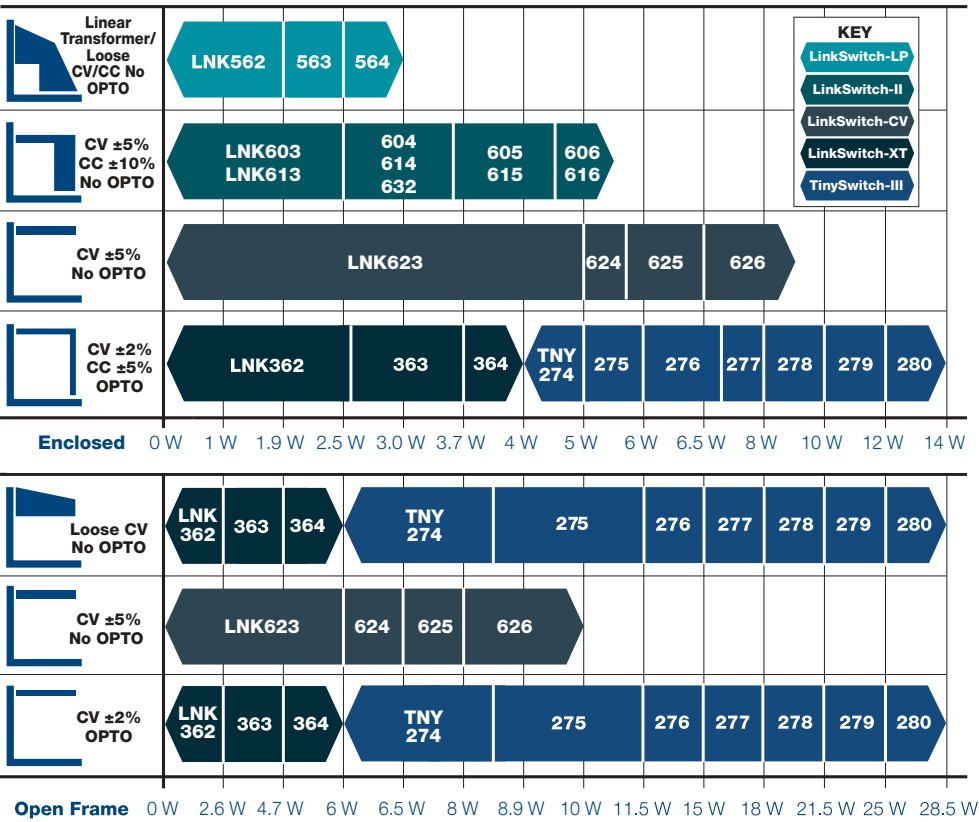

IC Product Tables and Design Examples

Very Low Power AC-DC, Non-Isolated Linear/Passive Supply Replacement (≤360 mA)

Product ⁴	Output Current ¹ (mA)		Output Current ¹ (mA)	
	MDCM ²	CCM ³	MDCM ²	CCM ³
LinkSwitch-TN	230 VAC ± 15%		85-265 VAC	
LNK302P/G/D	63	80	63	80
LNK304P/G/D	120	170	120	170
LNK305P/G/D	175	280	175	280
LNK306P/G/D	225	360	225	360

Additional Features:

- 700 V internal MOSFET rating
- Self-powered
- ON/OFF control
- Hysteretic thermal shutdown
- Power limiting
- Frequency jitter reduces EMI
- EcoSmart™ low standby/no-load power consumption

Notes:

1. Typical output current in a non-isolated buck converter. Output power capability depends on respective output voltage.
2. Mostly discontinuous conduction mode.
3. Continuous conduction mode.
4. Packages: P: DIP-8B, G: SMD-8B, D: SO-8C.

Very Low Power AC-DC Power Conversion (Up to 17 W)

Product ^{3,4}	Continuous Output Power (W)		Continuous Output Power (W)	
	Adapter ¹	Open Frame ²	Adapter ¹	Open Frame ²
LinkSwitch-CV	230 VAC ± 15%		85-265 VAC	
LNK623P/D	6.5	9	5.0	6
LNK624P/D	7	11	5.5	6.5
LNK625P/D	8	13.5	6.5	8
LNK626P/D	10.5	17	8.5	10
LinkSwitch-II	230 VAC ± 15%		85-265 VAC	
LNK603/613P/D	2.5	3.3	2.5	3.3
LNK604/614P/D	3.5	4.1	3.5	4.1
LNK605/615P/D	4.5	5.1	4.5	5.1
LNK606/616P/G/D	5.5	6.1	5.5	6.1
LNK632D	3.1	3.1	3.1	3.1
LinkSwitch-LP	230 VAC ± 15%		85-265 VAC	
LNK562P/G/D	1.9	1.9	1.9	1.9
LNK563P/G/D	2.5	2.5	2.5	2.5
LNK564P/G/D	3	3	3	3
LinkSwitch-XT	230 VAC ± 15%		85-265 VAC	
LNK362P/G/D	2.8	2.8	2.6	2.6
LNK363P/G/D	5	7.5	3.7	4.7
LNK364 P/G/D	5.5	9	4	6

Additional Features:

- 700 V internal MOSFET rating
- Self-powered
- ON/OFF control
- Hysteretic overtemperature protection
- Power limiting
- Frequency jitter reduces EMI
- EcoSmart low standby/no-load power consumption

Notes:

1. Minimum continuous power in a typical non-ventilated enclosed adapter measured at 50 °C ambient.
2. Minimum practical continuous power in an open frame design with adequate heat sinking, measured at 50 °C ambient.
3. Packages: P: DIP-8B, G: SMD-8B, D: SO-8C.
4. Packages: P: DIP-8C, G: SMD-8C, D: SO-8C.

Low Power AC-DC Power Conversion (Up to 36.5 W)

Product ³	Continuous Output Power (W)		Continuous Output Power (W)	
	Adapter ¹	Open Frame ²	Adapter ¹	Open Frame ²
TinySwitch-III	230 VAC ± 15%		85-265 VAC	
TNY274P/G	6	11	5	8.5
TNY275P/G	8.5	15	6	11.5
TNY276P/G	10	19	7	15
TNY277P/G	13	23.5	8	18
TNY278P/G	16	28	10	21.5
TNY279P/G	18	32	12	25
TNY280P/G	20	36.5	14	28.5

Additional Features:

- 700 V internal MOSFET rating
- Self-powered
- Hysteretic overtemperature protection
- Frequency jitter reduces EMI
- EcoSmart low standby/no-load power consumption
- On-time extension
- Latching output overvoltage protection
- Line undervoltage lockout
- Selectable current limit

Notes:

1. Minimum continuous power in a typical non-ventilated encased adapter with minimal heat sinking, measured at a device ambient of 50 °C.
2. Minimum continuous power in an open frame with adequate heat sinking. TinySwitch-III operates without bias winding.
3. Packages: P: DIP-8C, G: SMD-8C.

High Efficiency AC-DC Power Conversion (Up to 244 W)

Product ⁵	PCB Copper Area ¹			
	Adapter ² (W)	Open Frame ³ (W)	Adapter ² (W)	Open Frame ³ (W)
TOPSwitch-JX	230 VAC ± 15% ⁴		85-265 VAC	
TOP264V	21	34	12	22.5
TOP264K	30	49	16	30
TOP265V	22.5	36	15	25
TOP265K	33	53	20	34
TOP266V	24	39	17	28.5
TOP266K	36	58	23	39
TOP267V	27.5	44	19	32
TOP267K	40	65	26	45
TOP268V	30	48	21.5	36
TOP268K	46	73	30	50
TOP269V	32	51	22.5	37.5
TOP269K	50	81	33	55
TOP270V	34	55	24.5	41
TOP270K	56	91	36	60
TOP271V	36	59	26	43
TOP271K	63	102	40	66
Product ⁵	Metal Heat Sink ¹			
	Adapter ² (W)	Open Frame ³ (W)	Adapter ² (W)	Open Frame ³ (W)
TOPSwitch-JX	230 VAC ± 15% ⁴		85-265 VAC	
TOP264E/V	30	62	20	43
TOP265E/V	40	81	26	57
TOP266E/V	60	119	40	86
TOP267E/V	85	137	55	103
TOP268E/V	105	148	70	112
TOP269E/V	128	162	80	120
TOP270E/V	147	190	93	140
TOP271E/V	177	244	118	177

Additional Features:

- Multi-mode operation maximizes efficiency at all loads
- New eDIP™-12 package
 - Low profile horizontal orientation for ultra-slim designs
 - Heat transfer to both PCB and heat sink
 - Optional external heat sink provides thermal impedance equivalent to a TO-220
- Output overvoltage protection is user programmable for latching/non-latching shutdown with fast AC reset
 - Allows both primary and secondary sensing
- Line undervoltage detection prevents turn-off glitches
- Line overvoltage shutdown extends line surge limit
- Accurate programmable current limit
- Optimized line feed-forward for line ripple rejection
- 132 kHz frequency reduces transformer and power supply size
 - Half frequency option for video applications
- Frequency jittering reduces EMI filter cost
- Improved auto-restart delivers <3% of maximum power in short circuit and open loop fault conditions
- Accurate hysteretic thermal shutdown function automatically recovers
- Fully integrated soft-start for minimum start-up stress

Notes:

1. See Key Application Considerations section for more details.
2. Minimum continuous power in a typical non-ventilated enclosed adapter measured at +50 °C ambient temperature.
3. Minimum continuous power in an open frame design at +50 °C ambient temperature.
4. 230 VAC or 110/115 VAC with doubler.
5. Packages: E: eSIP-7C, V: eDIP-12, K: eSOP™-12.

Zero' Loss Automatic X Capacitor Discharge IC

Product ³	V_{DSS}	Max Total X Capacitance	Total Series Resistance ² (R1 + R2)
CAPZero			
CAP002DG	825 V	≤ 500 nF	1.5 M Ω
CAP012DG	1000 V		
CAP003DG	825 V	750 nF	1.02 M Ω
CAP013DG	1000 V		
CAP004DG	825 V	1 μ F	780 k Ω
CAP014DG	1000 V		
CAP005DG	825 V	1.5 μ F	480 k Ω
CAP015DG	1000 V		
CAP006DG	825 V	2 μ F	360 k Ω
CAP016DG	1000 V		
CAP007DG	825 V	2.5 μ F	300 k Ω
CAP017DG	1000 V		
CAP008DG	825 V	3.5 μ F	200 k Ω
CAP018DG	1000 V		
CAP009DG	825 V	5 μ F	150 k Ω
CAP019DG	1000 V		

Notes:

- IEC 62301 clause 4.5 rounds standby power use below 5 mW to zero.
- Values are nominal. RC time constant is <1 second with $\pm 20\%$ X capacitor and $\pm 5\%$ resistance from these nominal values.
- Package: D: SO-8.

Additional Features:

- Blocks current through X capacitor discharge resistors when AC voltage is connected
- Automatically discharges X capacitors through discharge resistors when AC is disconnected
- Simplifies EMI filter design – larger X capacitor allows smaller inductive components with no change in consumption
- Only two terminals – meets safety standards for use before or after system input fuse
- >4 mm creepage on package and PCB
- Self supplied – no external bias required
- High common mode surge immunity – no external ground connection
- High differential surge withstand – 1000 V internal MOSFETs

LinkSwitch-TN – Non-Isolated Dual Output Buck (RDK-138)

1.2 W, ± 5 V, 50 mA, 7 V / 12 V, 80 mA, 85 – 265 VAC INPUT BUCK DERIVED POWER SUPPLY

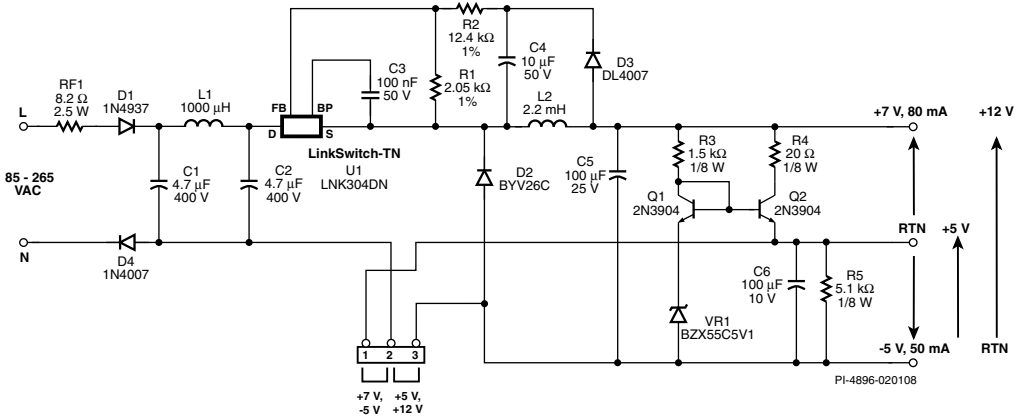

LinkSwitch-LP – Replacement for Unregulated Linear Transformer (DAK-85)

2 W, 6 V, 0.33 A, 90 – 265 VAC INPUT FLYBACK POWER SUPPLY

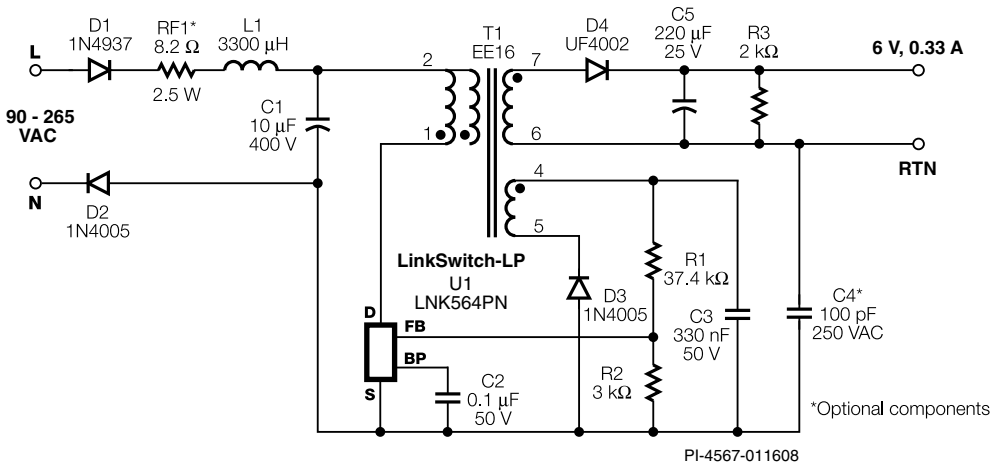

LinkSwitch-II – Low Power Constant Voltage, Constant Current Charger/Adapter (RDR-158)

5 W, 5 V, 1 A, 85 – 265 VAC INPUT FLYBACK POWER SUPPLY

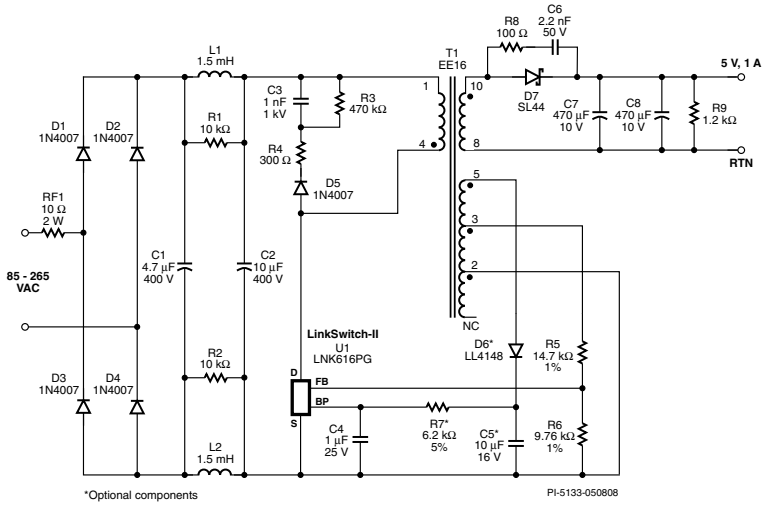

LinkSwitch-CV – Low Power Constant Voltage Adapter/Charger (RDK-201)

6 W, 5 V, 1.2 A, 90 – 265 VAC INPUT FLYBACK POWER SUPPLY

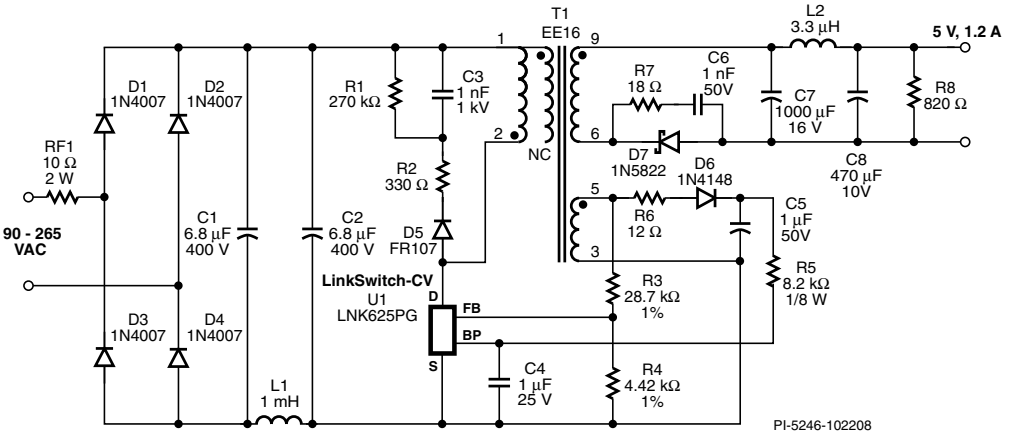

TinySwitch-III – Universal Constant Voltage Input Adapter (RDK-91)

12 W, 12 V, 1 A, 85 – 265 VAC INPUT FLYBACK POWER SUPPLY

