

DI-153 Design Idea

TinySwitch-III

1.25 W, Low Input Voltage Range Power Supply for Industrial Controls

Application	Device	Power Output	Input Voltage	Output Voltage	Topology
Industrial Controls	TNY274PN	1.25 W	18 – 30 VAC	5 V	Flyback

Design Highlights

- Low Input Voltage Range (18 – 30 VAC)
- Highly energy efficient
 - 65% efficiency
 - Extremely low no-load power consumption (<100 mW at 30 VAC)
- Auto-restart indefinitely withstands shorted output condition

Operation

Figure 1 shows a flyback converter using the TNY274PN device. The input AC is low voltage in the range of 18 to 30 V, and output DC is 5 V at 250 mA. Applications of such a power supply include auxiliary power supplies for industrial controls.

The AC mains are rectified and doubled by the input voltage doubler formed by D1, D2, C1 and C2 (Greinacher voltage doubler). Capacitors C1, C2 and C3 are of relatively large value. This ensures that the minimum DC bus voltage is above 50 V, the datasheet limit for minimum drain voltage to guarantee proper startup and functionality.

The TinySwitch-III (U1) uses on/off control, which offers a very simple feedback scheme and very fast dynamic response.

The controller in U1 receives feedback from the secondary through optocoupler U2, enabling or disabling the switching of its integrated MOSFET to maintain output regulation. The current through the LED in U2 represents the output voltage. A proportional current is then pulled out of the EN/UV pin. Switching cycles are skipped once the EN/UV disable threshold current (115 μ A) is exceeded. When the current out of the EN/UV pin falls below the disable threshold, switching cycles are re-enabled.

To improve efficiency at light loads, a bias winding is used. The bias winding disables the internal high voltage current source, which normally powers the IC from the DRAIN pin, thereby reducing power consumption. Diode DX1 and capacitor CX1 maintain the bias winding voltage. Resistor RX1 is sized so that IC supply charging current flows into the BP/M pin, disabling the internal current source at no-load.

Diode D4 rectifies the output of T1. Output voltage ripple is minimized by using a low ESR capacitor for C7. A post filter, comprising L2 and C8, attenuates the high frequency switching noise.

The output voltage is determined by the series sum of the voltages across VR1, R5, and the LED in U2. The values of R5 and R6 can be adjusted to fine-tune the output voltage of the supply. A TL431 can be used in place of VR1 for tighter output voltage regulation.

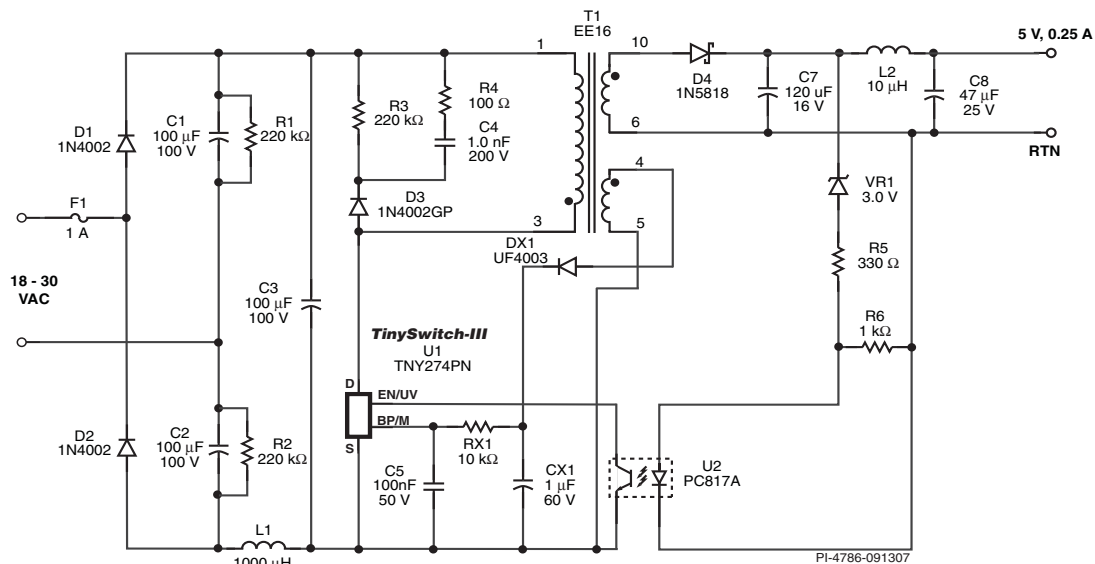

Figure 1. Schematic of a Wide Range Input, 5 V, 250 mA Power Supply Using TinySwitch-III

Key Design Points

- In the PIXIs spreadsheet, the value of AC input voltage should be twice the input voltage to represent a voltage doubler input.
- Use a slow blocking diode D3 in the clamp circuit. Use only a glass-passivated (GP) diode type to ensure a reverse recovery time of 2 μ s or less. If a GP diode is unavailable, a fast diode, such as FR107, may be used instead. These diode selections recycle some of the clamp energy and improve no-load efficiency.
- Capacitor C4 and resistors R3 and R4 form the snubber network. For maximum leakage energy recovery, maximize the value of R3 while maintaining peak drain voltage below 650 V.
- Design the bias winding circuit to provide approximately 600 μ A at no load to the BP pin.
- Design the transformer with relatively high value of reflected output voltage (VOR) for better efficiency. However, do not design with a VOR greater than the minimum DC bus voltage.
- Resistors R1 and R2 are voltage balancing resistors to compensate for the tolerances of electrolytic capacitors (C1 and C2).

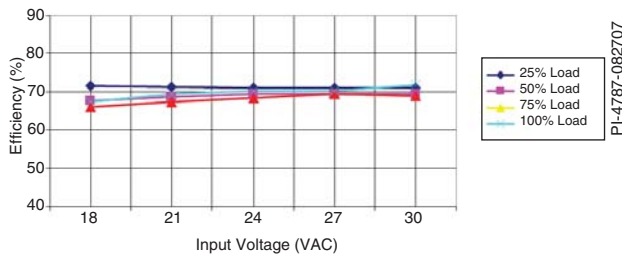

Figure 2. Efficiency vs AC Input Voltage

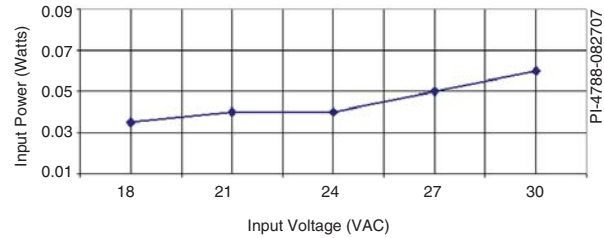

Figure 3. No-Load Input Power Consumption

Transformer Parameters

Core Material	EE16 NC-2H or equivalent, gapped for ALG of 193 nH/t ²
Bobbin	EE16, 10 pin, Horizontal
Winding Details	Bias: 32T x 2, AWG30, tape Primary: 64T x 1, AWG30, 3 layers of tape 5 V: 10T x 1, AWG28, TIW, 1 layer, tape
Winding Order	Bias (4-5), Primary (3-1), 5 V (10-6)
Primary Inductance	780 μ H, \pm 12%
Primary Resonant Frequency	1 MHz (minimum)
Leakage Inductance	80 μ H (maximum)

Table 1. Transformer Parameters. (NC = No Connection, TIW = Triple Insulated Wire)

Power Integrations
5245 Hellyer Avenue
San Jose, CA 95138, USA.
Main: +1 408-414-9200
Customer Service
Phone: +1-408-414-9665
Fax: +1-408-414-9765
Email: usasales@powerint.com

On the Web
www.powerint.com

Power Integrations reserves the right to make changes to its products at any time to improve reliability or manufacturability. Power Integrations does not assume any liability arising from the use of any device or circuit described herein. POWER INTEGRATIONS MAKES NO WARRANTY HEREIN AND SPECIFICALLY DISCLAIMS ALL WARRANTIES INCLUDING, WITHOUT LIMITATION, THE IMPLIED WARRANTIES OF MERCHANTABILITY, FITNESS FOR A PARTICULAR PURPOSE, AND NON-INFRINGEMENT OF THIRD PARTY RIGHTS. The products and applications illustrated herein (transformer construction and circuits external to the products) may be covered by one or more U.S. and foreign patents or potentially by pending U.S. and foreign patent applications assigned to Power Integrations. A complete list of Power Integrations' patents may be found at www.powerint.com. Power Integrations grants its customers a license under certain patent rights as set forth at <http://www.powerint.com/ip.htm>.

The PI logo, TOPSwitch, TinySwitch, LinkSwitch, DPA-Switch, PeakSwitch, EcoSmart, Clampless, E-Shield, Filterfuse, StackFET, PI Expert and PI FACTS are trademarks of Power Integrations, Inc. Other trademarks are property of their respective companies. ©2007, Power Integrations, Inc.